

Rearing Cage

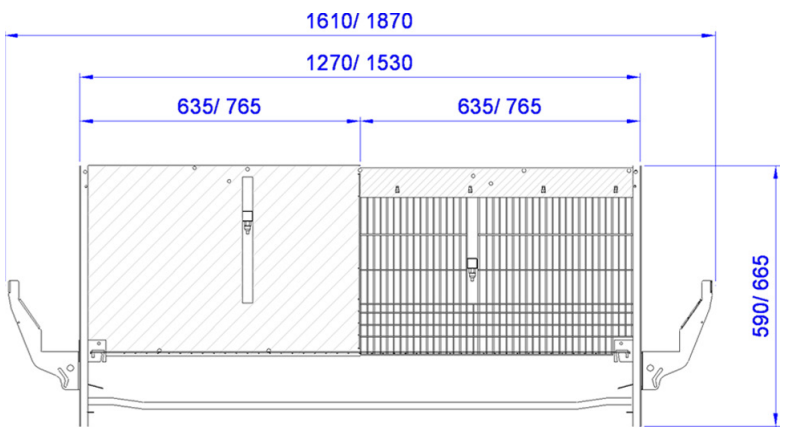

Rearing Cage

- Compartment length: 965 mm
- Compartment depth: 635/765 mm
- Row width: 1.61/1.87 m
- Tier height: 590/665 mm
- Compartment surface: 6.127/7.382 cm²
- Height 4 tiers: 2.66/2.96 m

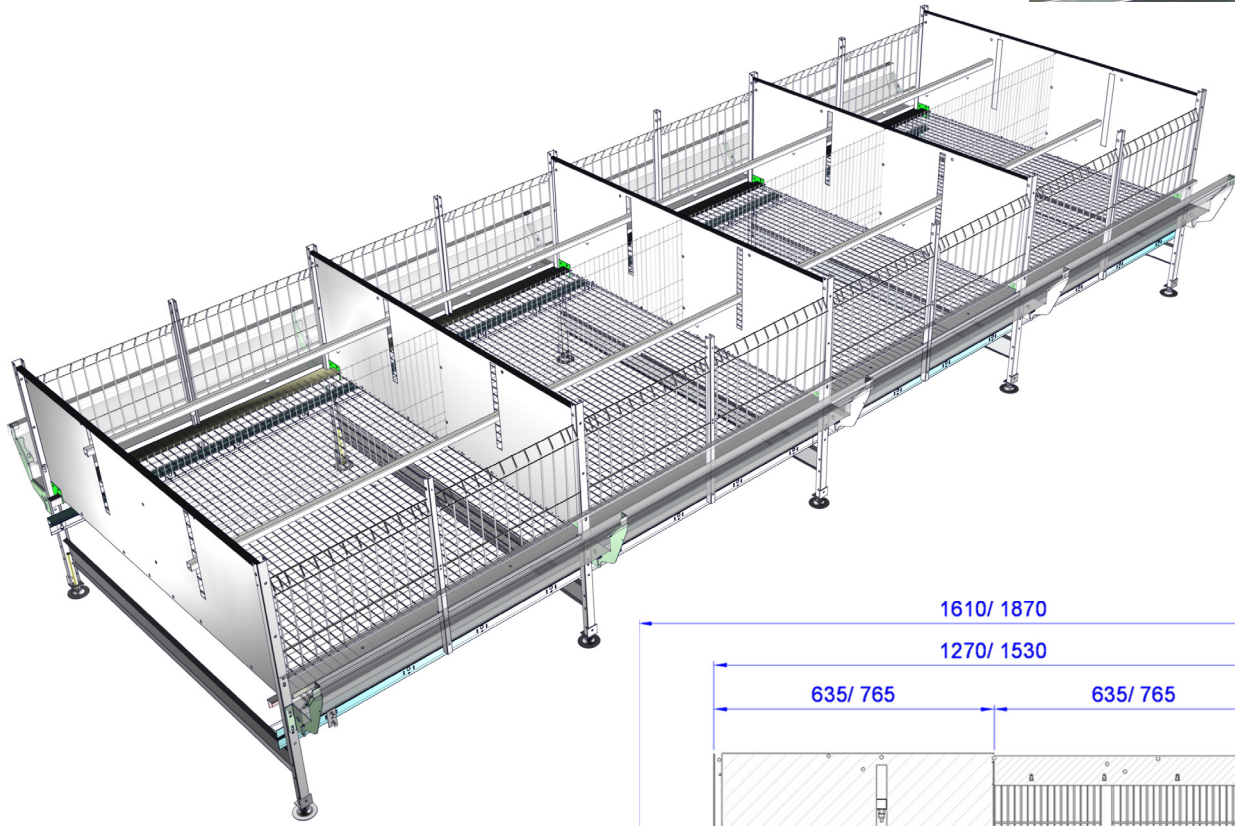

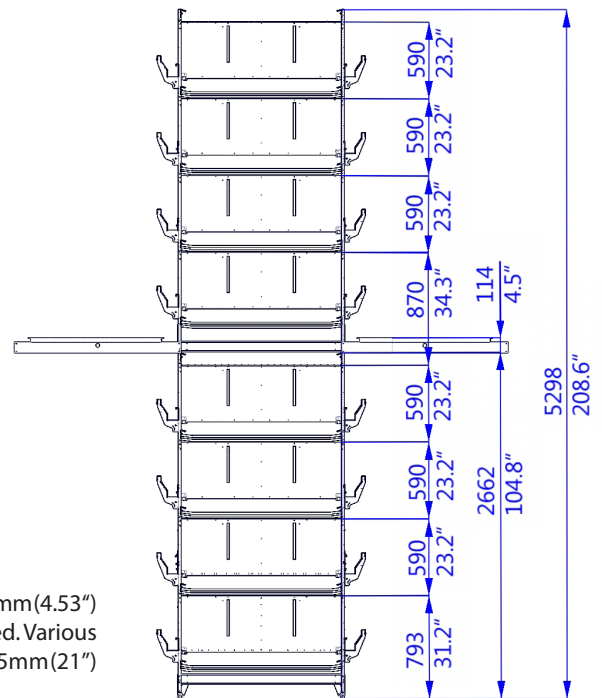
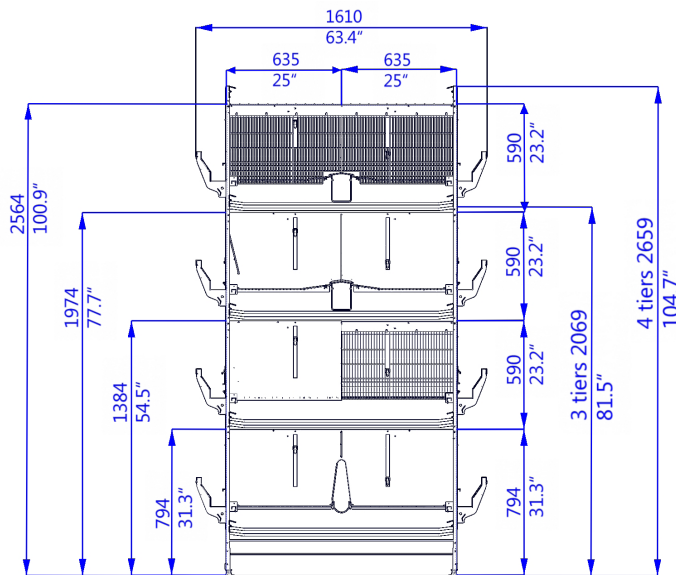

La hauteur totale peut être réduite de 115 mm (4,53") si l'unité de fumier d'entraînement de chaîne est en retrait. Différents types peuvent être fournis, la hauteur des niveaux de 535 mm (21") au lieu de 590 mm (23,2").

The total height can be reduced by 115 mm (4.53") if the manure belt drive unit is recessed. Various types can be supplied, tier height of 535 mm (21") instead of 590 mm (23.2").

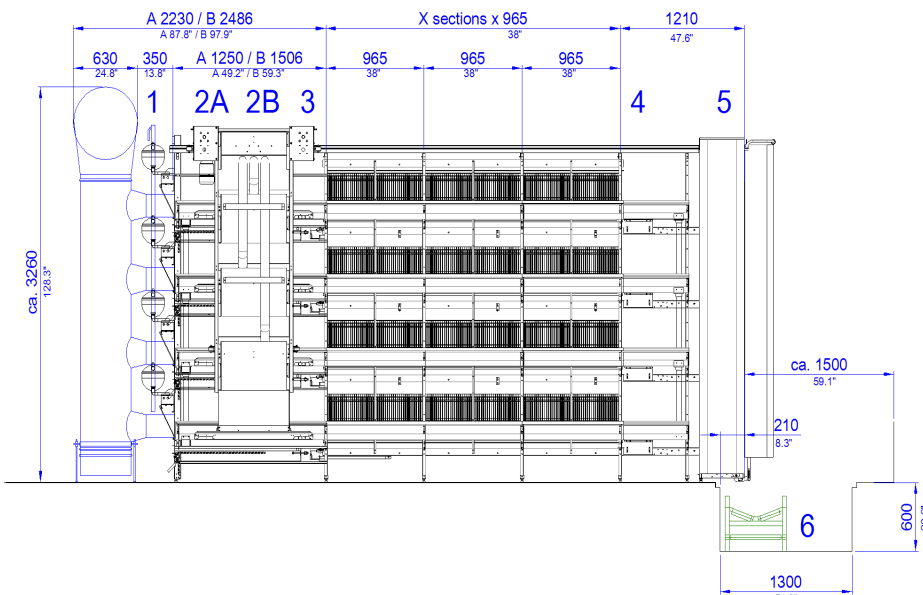

1. Watering System
2. a. Feed chain drive / b. feed hopper
3. Reverse station
4. Reverse station feed chain
5. Manure drive station
6. Cross conveyor belt

1. Système d'abreuvement
2. a. Entraînement de la chaîne d'alimentation / b. trémie d'alimentation
3. Station de retour du tapis à fiente n°
4. Station de retour de la chaîne d'alimentation n°
5. Station d'entraînement du tapis à fiente
6. Convoyeur transversal

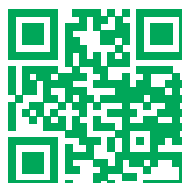
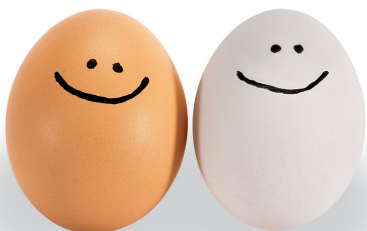

Made in Germany.

Hellmann Poultry GmbH & Co. KG · Kopernikusstr. 6-10 · 49377 Vechta
P.O. BOX 1232 · 49361 Vechta · Germany · Phone +49 4441 9259-0
Fax +49 4441 9259-50 · www.hellmannpoultry.com